

**2.0 ton  
CBD20  
AC Electric Pallet Trucks**





■ **Multi-function instrument**

It includes the hour meter, and battery discharge indicator (BDI) to inform the operator to recharge the battery in time.

■ **Operator handle**

Ergonomic designed handle is easy and comfort controlled.

■ **Electric power steering system (EPS)**

The steering system is not connected with the driving system to prevent any disadvantage that they move together, when the handle turning the driving unit no longer needs turning accordingly. EPS is more effective and precise, its module design and malfunction display provides fast and simple self diagnosis function.

■ **AC drive motor and Curtis AC controller**

AC drive motor offers excellent power performance even on full load, Curtis controller has advanced cooling system and compact and sealed design.

■ **Sealed stabilizer wheel**

Special design sealed stabilizer wheel not only eliminates the fiber material intertwined, but also ensure the stability during driving and steering, effectively reduces the sway and side turn over.

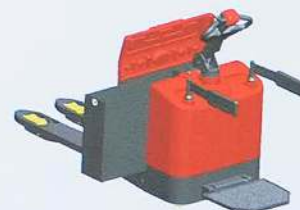

CBD20-460 has the following special characteristics:

■ **Drive wheel friction automatic compensation system**

Central pressure boost cylinder linked with the hydraulic system, the cylinder pressure is increased accordingly as the load increasing, it add more pressure to the driving wheel to ensure the best friction on the ground, this design solves the problem in the industry that the driving wheel is easy skid with full load.

■ **Easy change battery side extraction**

The battery can be pulled out from side makes the battery changing is convenient and quickly.

Characteristics			
1	Model Designation		CBD20
2	Configuration Number		460
3	Power type		electric(battery)
4	Operator Type		stand - on
5	Load capacity	Q(kg)	2000
6	Load center	c(mm)	600
7	Wheelbase	y(mm)	1460
			1390
Wheels			
8	Tyre Type		PU
9	Tyre Size, drive	mm	φ 248x75
10	Tyre Size, load	mm	φ 80x80
11	Stabilizer wheels (size)	mm	φ 115x55
12	Wheels number,Stabilizer/load(x=driving wheels)		1X+2/4
13	Tread,rear	b11 (mm)	355/385/415/500
Dimensions			
14	Handle in neutral position	h14(mm)	1455
15	Overall Length	L1 (mm)	1910/1960
16	Length to face of forks	L2(mm)	760
17	Overall Width	b1(mm)	790
18	Maximum Lifting height	h3(mm)	120
19	Height,fork lowered	h13(mm)	85
20	Fork Thickness	s(mm)	55
21	Fork Width	e(mm)	185
22	Fork Length	L(mm)	1150/1200
23	Width overall forks	b5(mm)	540/570/600/685
24	Outside turning radius,platform up/down	Wa( mm )	1465/2140
25	Right angle stacking aisle width for pallets 800×1200 mm, platform up/down(clearance: 200)	As1(mm)	2140/2815
26	Right angle stacking aisle width for pallets 1000×1200 mm, platform up/down(clearance: 200)	As2(mm)	2225/2900
27	Travel speed,with/without load	km/h	6/6
28	Lifting speed,with/without load	mm/s	40/45
29	Lowering speed,with/without load	mm/s	35/20
30	Gradeability,with/without load	%	5/7
31	Service Brake		Electromagnetic brake
Motor			
32	Drive motor power	kW	AC1.5
33	Lift motor power	kW	DC2
34	Battery voltage/ capacity	V/ Ah	24/270
			24/210
Weight			
35	Battery Weight	kg	252
36	Weight (include battery)	kg	854
			190
			612

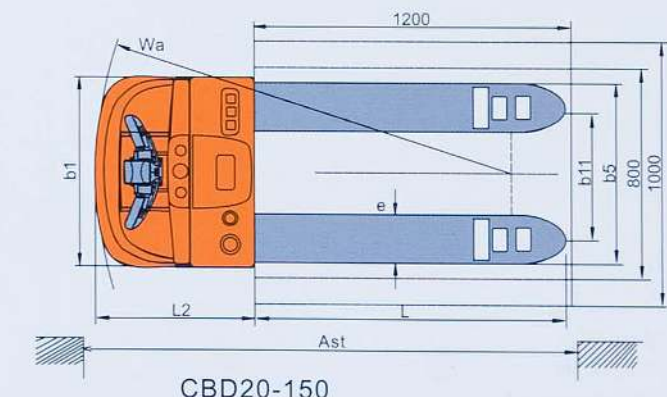
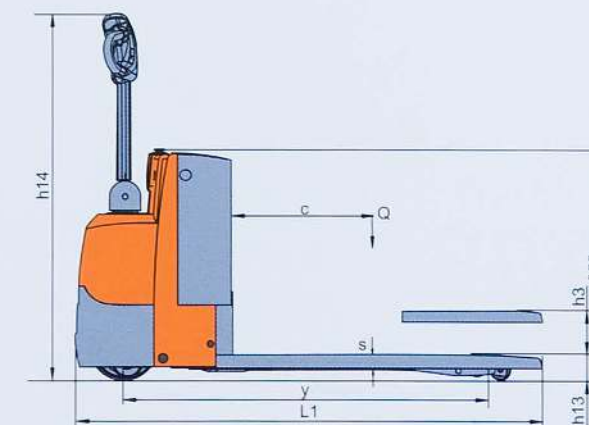



**HELI**

**2.0 ton  
CBD20  
AC Electric Pallet Trucks**

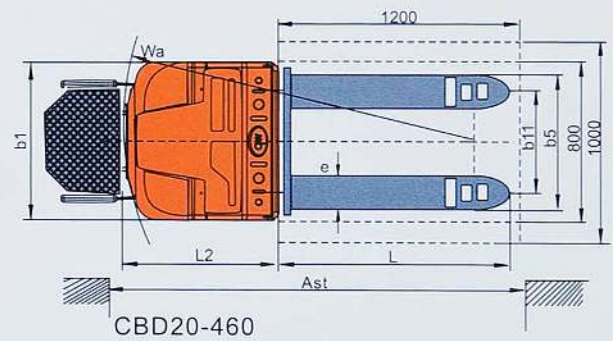
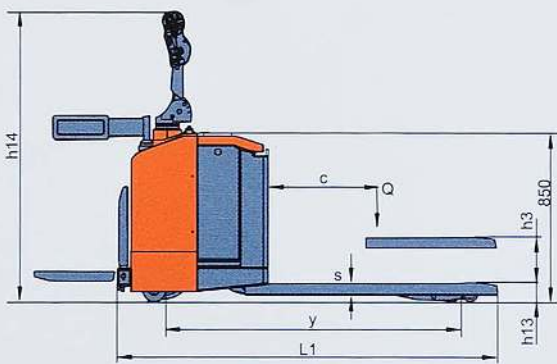

**HELI**

Heli UK • Unit 10 • Hewitts Ind Est • Elmbridge Road  
Cranleigh • Surrey • GU6 8LW • United Kingdom  
[www.heliuk.com](http://www.heliuk.com)